

锁紧螺母

d 10-280mm-MB1

参数信息:

尺寸mm :

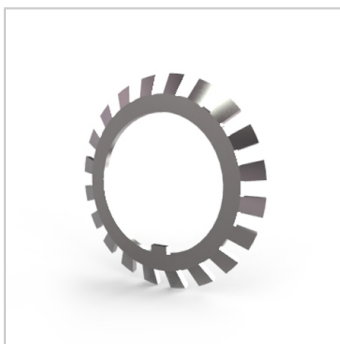
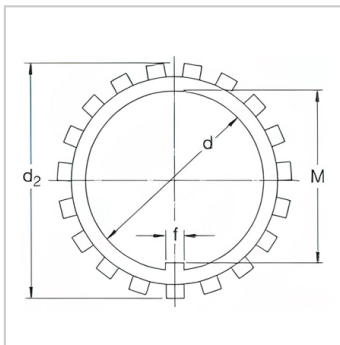
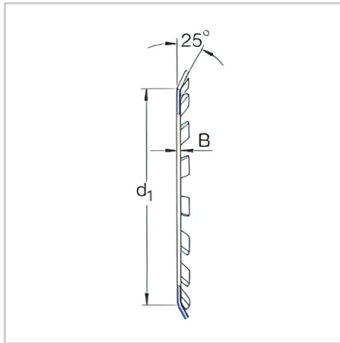

| | |
|------|-------|
| d : | 12 |
| d : | 17 |
| d : | 25 |
| B : | 1 |
| f : | 3 |
| M : | 10.5 |
| 质量 : | 0.002 |
| 型号 : | MB1 |

: